

Product Information

VD101H realizes 560TVL(Day)/600TVL(Night) High Resolution with 1/3" Sony Super HAD CCD II and color signal removal technology at nighttime. Highly improved Image process engine and Sens-up technology detect subject clear in B/W mode under low light condition of 0.00001 Lux.

3D adaptive Noise Reduction Filter effectively removes the noises from the image signal under the low light and helps to reproduce a more vivid and clear image.

With the built-in HSBLC(Highlight Suppression BLC) technology, the unit can make the selected highlights masked and the dark brightened simultaneously to capture the numbers on the License Plate clearly at nighttime.

Multi-lingual OSD menu settings, RS-485 communication, Motion Detection & Privacy Masking are basically supported. They grade up the surveillances efficiently.

Perfect 3-Axis structure gets correct videos in every direction.

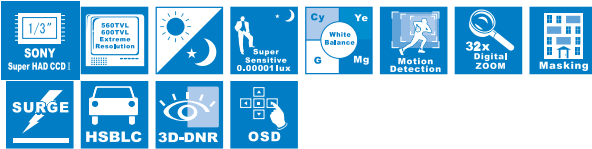

Key Features

- 1/3" SONY Super HAD CCD II
- 560 TVL at Day / 600 TVL at night
- 0.00001 Lux at F1.2 (SENS-UP remarkable low lux performance)
- 3DNR (3D Noise reduction)
- HSBLC (Highlight Suppression BLC)
- Privacy zone (8 zones)
- Motion detection zone (4 zones)
- Surge voltage input protection built-in
- RS-485 remote control (Pelco-D)
- Multi-lingual OSD menu
- 12VDC, 12VDC / 24VAC dual power (Non-polarity power input)
- Tool-free 3-Axis

Perfect 3-Axis

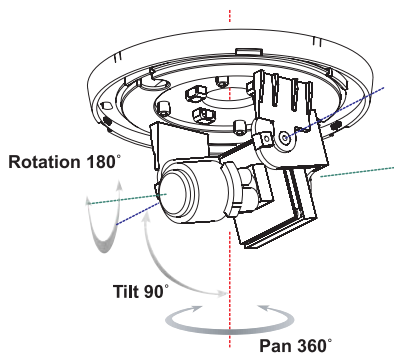

Model optional

VD101HQ	Sony HQ1, 560/600TVL, Monofocal/Varifocal lens 12VDC, 12VDC/24VAC
----------------	--

MODEL	VD101H
Image sensor	STD : 1/3" Sony Super HAD CCD II
Effective Pixels	NTSC : 768(H) x 494(V) PAL : 752(H) x 582(V)
H. Resolution	NTSC : 560TV Line(Day) / 600TV Line(Night) PAL : 550TV Line(Day) / 590TV Line(Night)
Synchronizing system	Internal
Scanning system	NTSC : 525 Lines PAL : 625 Lines 2:1 Interlaced
Video output	1.0Vp-p Composite. 75 Ohms
S/N ratio	More than 52dB (AGC Off)
Min. illumination	0.00001Lux/F1.2(Sens-up), 0.2 Lux/F1.2
Shutter Speed	NTSC : 1/60~1/100,000 sec. PAL : 1/50 ~ 1/100,000 sec.
Gamma correction	Standard Y = 0.45 (OSD)
White Balance	2,000°K ~ 20,000°K Auto
Gain Control	Standard : 6dB ~ 40dB, Off / Low / Middle / Hig
Smear Effect	0.005%
Power source	12VDC, 12VDC / 24VAC Dual Power
Operating current	200mA / 12VDC, 100mA / 24VAC
Iris Control	DC / MANUAL
Lens	2.8~11mm Varifocal DC Iris Lens / F1.2
Lens Option	2.9 / 3.6 / 4.3 / 6 / 8 / 12 / 16mm
Operating Temperature	14°F ~ 122°F (-10°C ~ +50°C)
Humidity	Within 90% RH
Measurement(mm)	134(Ø) x 91.7(H)
Weight (Approx.g)	800
OSD Menu	
White Balance	ATW / PUSH / MANUAL/AWC
Sens-up	x2 ~ x128
Privacy Masking	Off / On (8 programmable zones)
Motion Detection	Off / On (4 zones)
Digital zoom	Off / On (x1 ~ x32)
3DNR	Off / On

Dimension

